

RENOLD

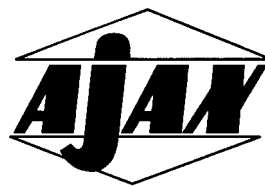

QE Quadra-Eccentric Vibrators

Applications for the Food Processing Industry

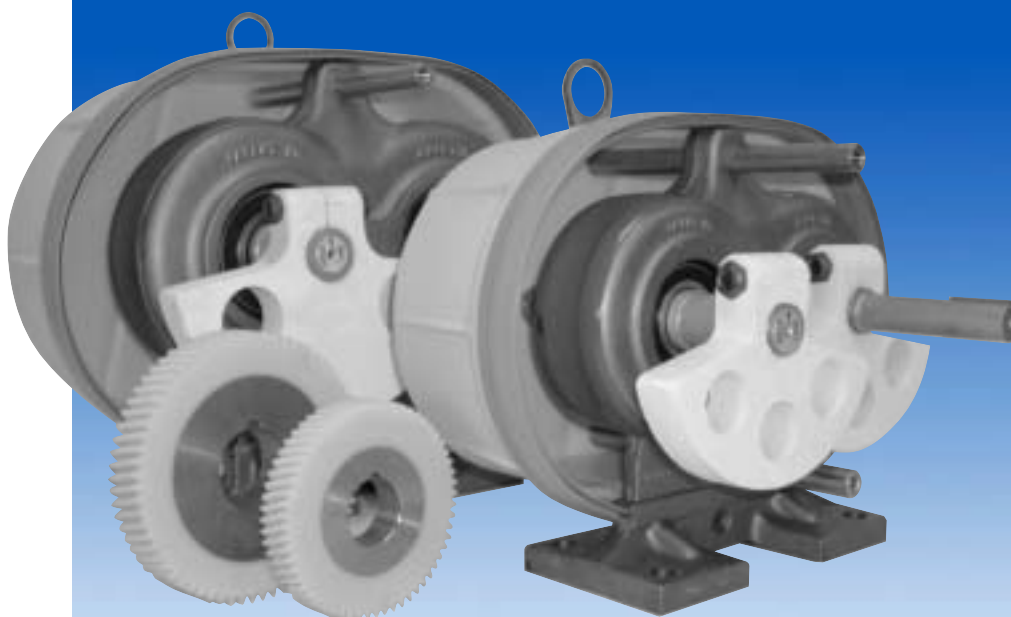

Lubrication free gear set

Quiet operation 68-70 DbA

Changeable eccentricity

Coupled dual vibrators

Direct factory application engineering assistance

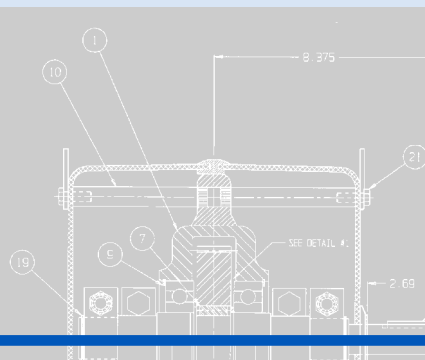

U.S. Patents: 4,942,776
5,231,886

RENOLD



AJAX QE Quadra-Eccentric Vibrators

The Ajax Quadra-Eccentric vibrator was developed for all oil drip free and sound sensitive applications in the food processing industry.

- Gear set that requires no lubrication—no oil leaks
- Units operate in the range of 68-72 DbA
- Nickel plated shafts
- Polyamide 12 plastic driver gear
- Changeable eccentric weights
- Models 512 and 675 create a force output range from 400-4,774 lbs. with an operating frequency range of up to 1200 RPM. See rated RPM.

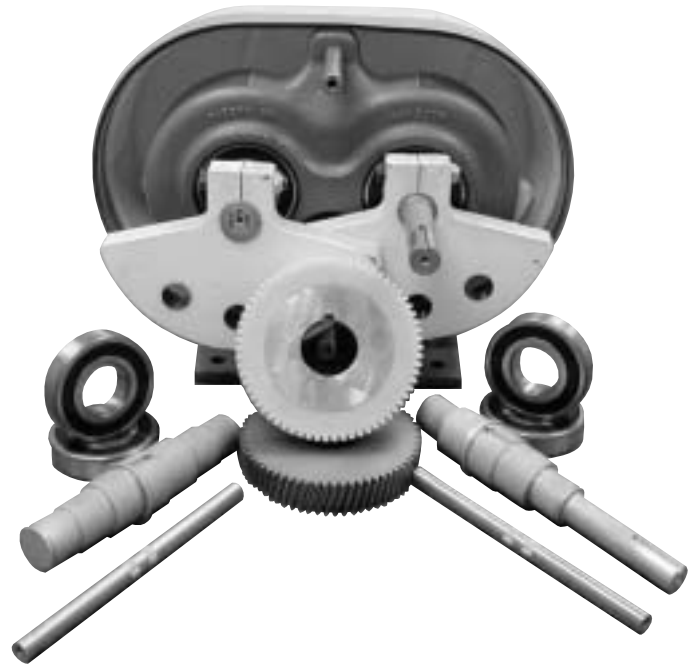

All eccentric weights are manufactured in cast steel. Both model ranges (the QE 512 and QE 675) have only two different size castings to cover the range from A to G.

Simply select which force output you require and remove the appropriate mass by drilling the weight. This gives you the ability to change the force output very quickly, either on your shop floor prior to dispatch or when in use.

Dual QE Vibrators

As the demand in processing requires greater production, it also requires larger equipment which equates to more force output from your vibrator. Renold Ajax has tested and commissioned dual QE vibrators for such applications. Drive shafts are assembled left- and right-hand and connected with a flexible coupling.



Lubrication-free Gear Set Vibrator

The QE Vibrator was introduced to the market after two years of development and rigorous testing, both in the plant and in the field. Increased quality and value have been achieved as a result. For example, stress relieving of the nylon gear blanks and hobbing the gear teeth individually to AMGA 9 standard, improved the quality and performance of the QE range. Today, the QE Vibrator not only meets industry expectations, but will out-perform competitive models when correctly selected and operated in line with the information given in this brochure.

Selecting a QE Vibrator

When a QE Vibrator is directly attached to a trough it is referred to as a "Brute Force" design. It is very simple to calculate the necessary vibrator by finding the required force output (Fo) projecting the desired stroke. The stroke, also referred to as amplitude (peak to peak), is the resultant action produced by the vibrator when properly isolated. As a general rule, brute force conveyors should operate at 0.375" stroke @ 900 RPM under load. The feed rate will most likely be considered to be approximately 35 FPM.

$$\text{Stroke} = \frac{F_o \times C}{Twt \times f^2}$$

Where:

- Fo = the total force output of the vibrator(s)
- C = a constant having a numerical value of 70470.91
- Twt = total weight, combined value of the trough, vibrator(s) weight and load
- f² = frequency squared
- ppcf = pond per cubic foot

Pre-Design

Example: Find the QE Vibrator size for a conveyor needing to deliver 5 TPH of sand @ 100 ppcf. Assume the pan width to be 18" wide and 72" long. Also for this example, assume the trough weight is 205 lbs. and the QE Vibrator @ 150 lbs.

$$5 \text{ TPH} = \frac{60 \text{ sec.} \times 1.0 \times 18" \text{ wide} \times \text{depth} \times 100 \text{ pcf} \times 35 \text{ FPM}}{144 \text{ in.}^2 \times 2000 \text{ lbs.}}$$

The resulting depth is 0.38". The sides of the trough should be a minimum of twice this value. This depth is the end of the dynamic angle of repose as it leaves the trough. The inlet will be much greater.

Find the load of material in the trough:

$$\frac{0.38" \times 18" \times 72"}{12" \times 12" \times 12"} \times 100 \text{ pcf} = 28.5$$

Find the total vibrated weight Twt:

$$\frac{205 \text{ lbs.}}{\text{trough}} + \frac{150 \text{ lbs.}}{\text{vibrators}} = \frac{28.5 \text{ lbs.}}{\text{load}} = 383.5 \text{ lbs.}$$

$$\text{Stroke } .375" = \frac{F_o \times 70470.91}{383.5 \text{ lbs.} \times 900^2}$$

Fo = 1653 lbs. minimum for a vibrator

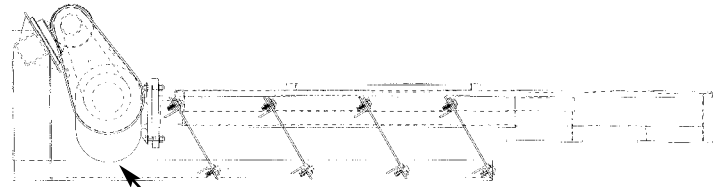

Drill (2) 3/8" holes in both plastic covers, see ***NOTE**.

Further:

$$F_o = 3.41 \times 10^{-4} \times f^2 \times ER$$

Or

$$ER = \frac{F_o}{3.41 \times 10^{-4} \times f^2}$$

If you supplement 1653 lbs. for Fo, the required ER (unbalance, ft. lb.) value is 5.98.

Refer to the QE Vibrator chart on page 6 and select the vibrator on unbalanced ER value equal to the value calculated, which is a model QE 675A.

Once the QE Vibrator is mounted on the trough, operate the unit and check the feed rate and stroke. If parameters have changed after the "pre design," such as trough weight, vibrator and loads, you may find it necessary to either increase or decrease the eccentricity, thereby changing the stroke. Simply remove the covers and change out the weights. QE Vibrators can be purchased as core units and the eccentric weights sold separately. Refer to pages 4-5 as weights can be altered, changing the ER value by simply drilling and removing mass. Consult the factory when doing this.

***NOTE:** Do not exceed the maximum RPM shown on page 6. The maximum ambient room temperature of all units is 100 degrees Fahrenheit, or 37.7 degree Centigrade. Always drill (2) 3/8" diameter holes at the lowest point through each of the plastic covers to allow for water drainage when units are subjected to wash down. If holes are not drilled, this will cause corrosion and washout of the bearing grease, thus voiding the warranty of this product.

Ajax QE Vibrator Means Flexibility

“Core” units can be purchased. Included are the basic housing sub-assembly and fastener hardware kit less the four eccentric weights and plastic covers with seal.

Complete models can also be purchased. You must be accurate in your designs to predict the required stroke. If you find that design needs to change as your project progresses, the QE Vibrator will provide maximum flexibility very quickly since it is so easy to change the weights, and therefore the force.

If flexibility in your conveyor design is a necessity on the lower end of an A through D range, simply purchase for your stock the “Model D” machined weight for either 512 or 675 QE Vibrators. The “Model D” machined weights can be transformed into a model “A through C” version by drilling the appropriate diameter hole through the weight. Always re-stamp the new weight for future identification. All four weights fitted into the one QE Vibrator must be identical.

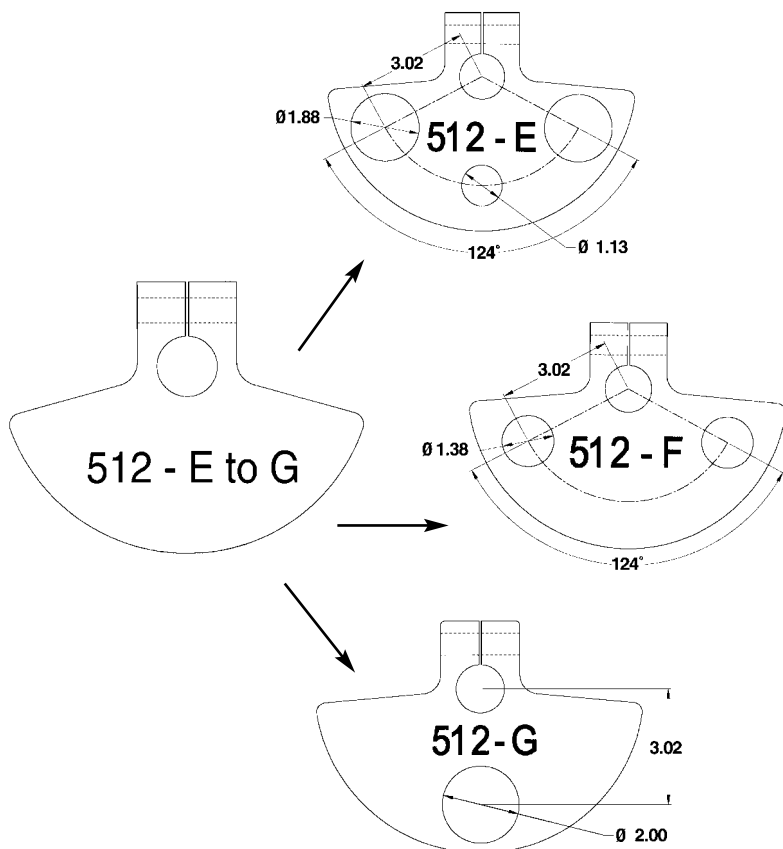
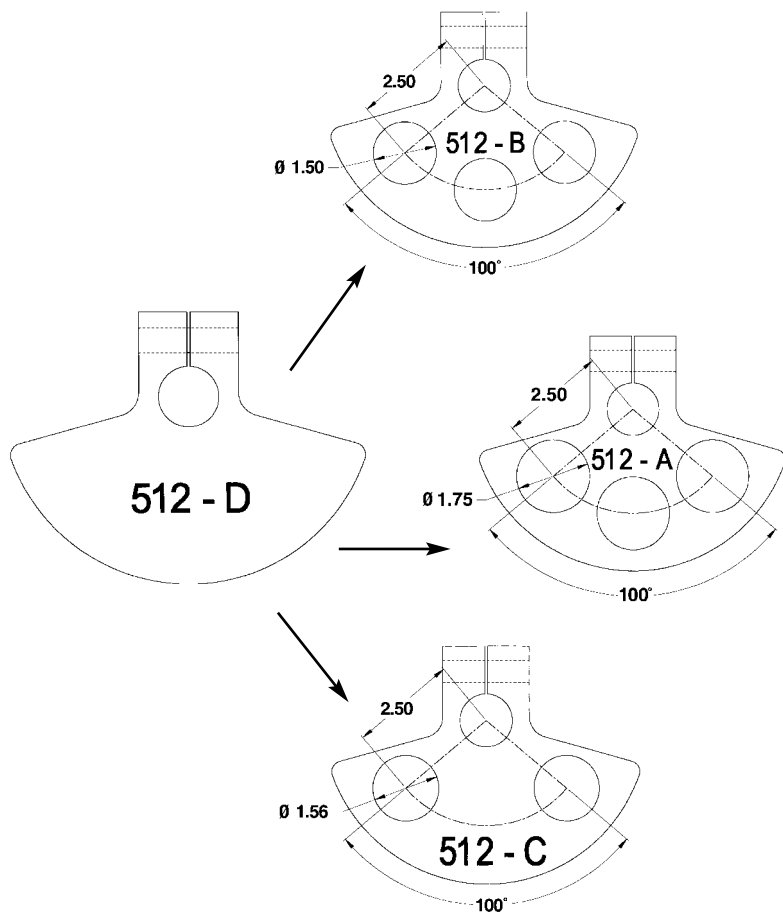

The model E to G weight cannot be used unless it is drilled for either a model E or F weight. The model G weight must be specially drilled at the factory level and filled with lead.

This new development gives us the ability to change out the weights very quickly.

If you do not have the capability of accurately drilling these holes, you must purchase weights from the factory.

Refer to page 3 for calculating the required stroke. Remember the total weight (Twt) is the combined weight of the trough, vibrator and the dynamic load.

The warranty of the Renold Ajax QE Vibrator is valid only if they are selected and operated within the guidelines set forth in this brochure. If you have any questions on selection or operation of these QE models, please contact the Renold AJAX factory for assistance.

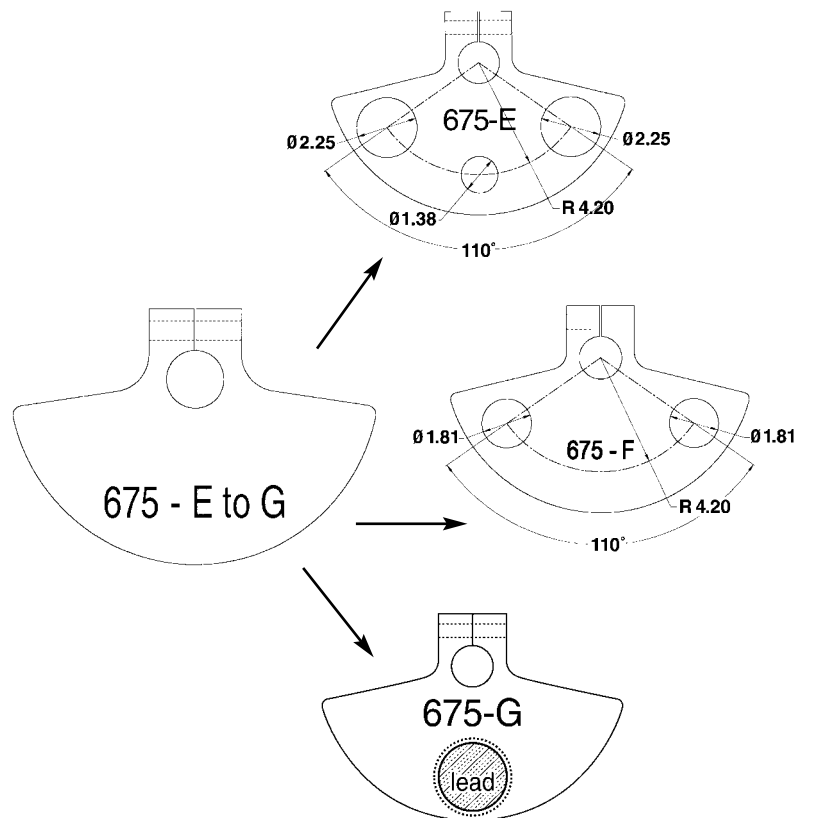
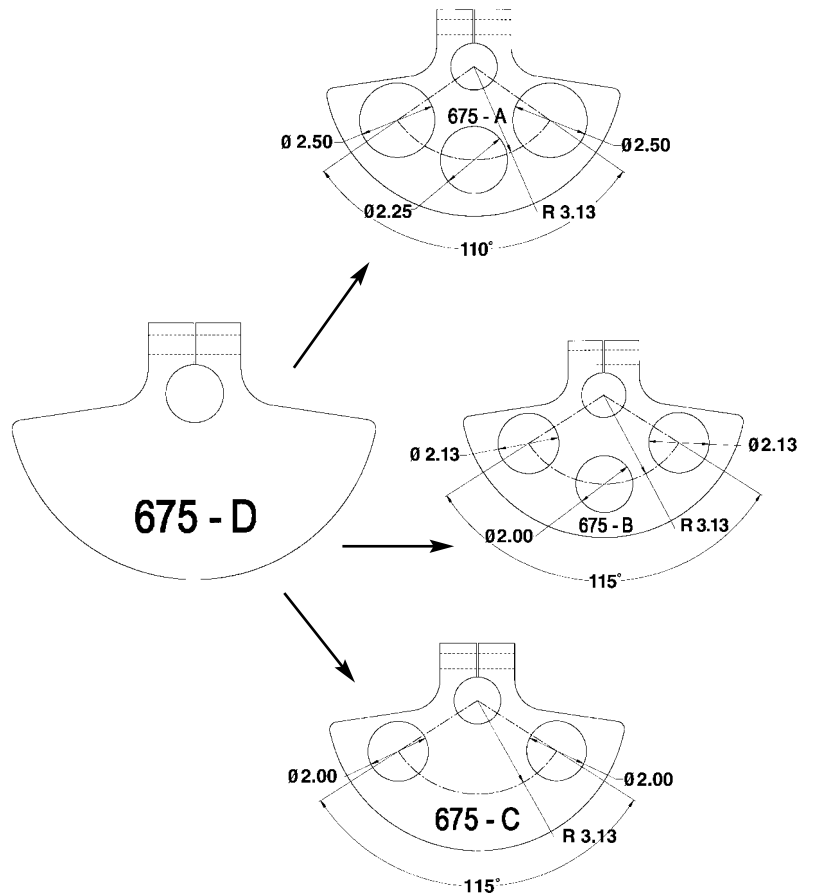

Ajax QE Quadra-Eccentric Vibrators

QE 512 Specifications and Dimensions

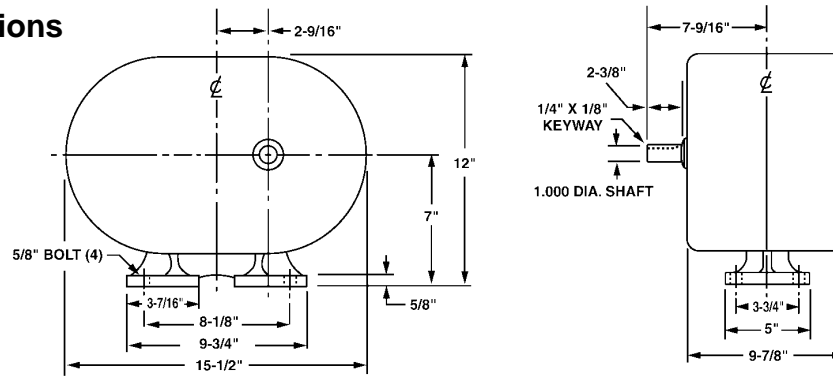

Model	Unbalance (ER) LB.FT.	Motor HP*	Force @ 700 RPM	Force @ 850 RPM	Force @ Max. Rated RPM	Unit Weight
QE512-G	6.00	1.0	1003	1478	2946 @ 1200	96
QE512-F	5.20	1.0	869	1281	2553 @ 1200	86
QE512-E	4.50	1.0	755	1114	2220 @ 1200	81
QE512-D	3.85	.75	643	948	1891 @ 1200	86
QE512-C	3.35	.75	560	825	1645 @ 1200	79
QE512-B	2.90	.75	483	712	1419 @ 1200	76
QE512-A	2.50	.75	418	616	1228 @ 1200	73

*HP requirement may vary with application—value given is guide for estimating.

QE 675 Specifications and Dimensions

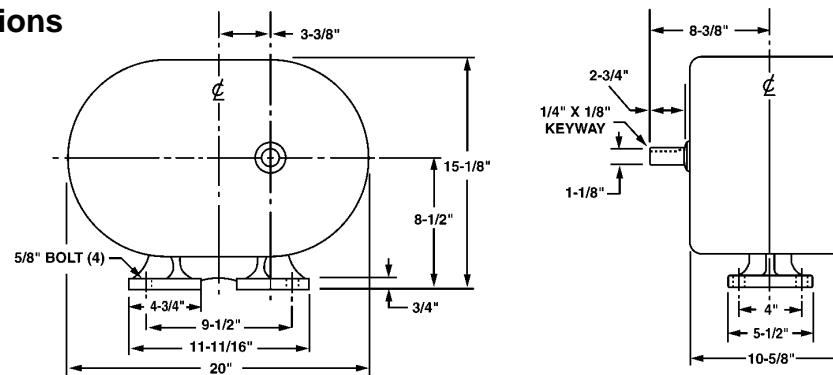

Model	Unbalance (ER) LB.FT.	Motor HP*	Force @ 700 RPM	Force @ 850 RPM	Force @ Max. Rated RPM	Unit Weight
QE675-G	14.0	2	2339	3449	4774 @ 1000	180
QE675-F	12.25	1 1/2	2047	3018	4694 @ 1060	166
QE675-E	10.75	1 1/2	1796	2649	4436 @ 1100	159
QE675-D	9.25	1 1/2	1546	2279	3817 @ 1100	152
QE675-C	8.0	1	1337	1971	3301 @ 1100	161
QE675-B	7.0	1	1170	1725	2888 @ 1100	152
QE675-A	6.0	1	1003	1478	2476 @ 1100	146

*HP requirement may vary with application—value given is guide for estimating.

The warranty of every QE Vibrator is valid only when the guidelines set forth in this text are exercised for operation. If you have questions regarding the operation of these models, please consult the factory immediately.

Conveyor Parts

When purchasing your QE Vibrator or AJAX Shaker, complete your design with complimentary parts such as pan arm isolators or fiberglass belt guards. A single pan arm is capable of loads up to 75 lbs., while pan arms with booster springs are capable of 125 lb. loads.

Renold also provides other isolation devices such as fiberglass leaf springs, coil springs, booster springs and repair kits for your Vibrator-Shaker needs. Contact Customer Service at 800-879-2529 Extension 248, for more information.

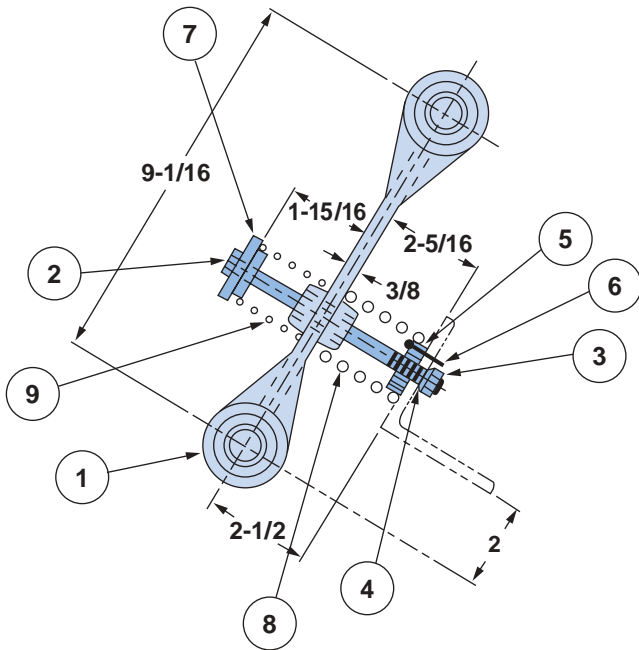

The #26W-3 One-piece Pan Arm Assembly replaces the #25W-3 three-piece assembly. Items 8 and 9, coil springs, are used for amplification of stroke only. Booster springs are used with applications to hold up the pan under heavy loads.

Item	No. Required	Description	Part No.
1	1	26W-2 Pan Arm	10202
2	1	Bolt	701-037-16-550
3	1	Hex Nut	765-037-16-000
4	1	Lockwasher	775-037-00-000
5	1	Rubber Bushing	10111
6	2	Cotter Pin	789-009-00-150
7	1	Stepped Washer	10207
8	1	Coil Spring	10203
9	1	Coil Spring	10206



Belt Guard Kits

Renold AJAX stocks three sizes of fiberglass belt guards with metal backs and posts. The metal plate is provided with sufficient clearance holes for the motor/shaker shafts. It requires fitting after the motor/shaker is assembled.

A stiffener is then welded to the metal plate and secured to the base. After the sheaves and belts are fitted, the fiberglass guard can be bolted to the post.

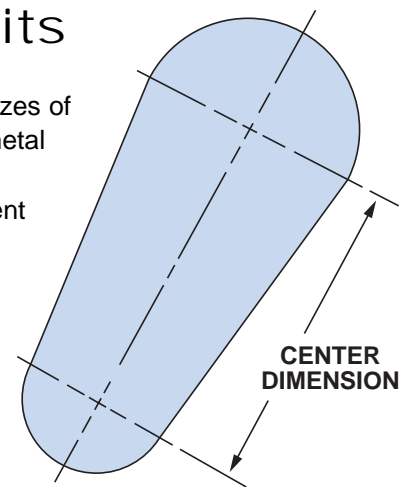

Drawing	Part Number		Center Dimension	Shaker Sizes
	Mild Steel	304SS		
9W-419	10400	10403	13"	5, 6, 8, 512
9W-420	10401	10404	16-1/2"	10, 12, 675
9W-421	10401	10404	25"	20



RENOLD

AJAX

Distribution Network

UNITED STATES

Headquarters
100 Bourne Street
Westfield, NY 14787-9706
Contact: Dave Anderson,
1-800-879-2529
Fax: 1-716-326-6121
Email: renold@cecomet.net

CANADA

Renold Canada Ltd.
121 Roy Boulevard, Brantford,
Ontario N3T 5N4 Canada
Contact: Doug MacDonald,
519-756-6118
Fax: 519-756-1767

UNITED KINGDOM

Renold House, Styal Road
Wythenshawe, Manchester
M22 5WL
Contact: Keith Spencer,
0161-437-5221
Fax: 0161-437-7782
Email: keith.spencer@renold.com

Put **RENOLD** / **AJAX** to work for your most demanding applications

SHAKER DRIVES

Throughout the world, Renold's AJAX Shaker Drives are recognized as energy efficient units that are adaptable to countless new and unusual application possibilities. Standard applications include open and enclosed pan conveyors, screeners, feeders, packing tables, dewatering units, tampers, electronic test tables and cable laying plows. Seven basic sizes are offered, each of which is available with a variety of eccentric weight selections, so a wide range of performance is possible for a given size.

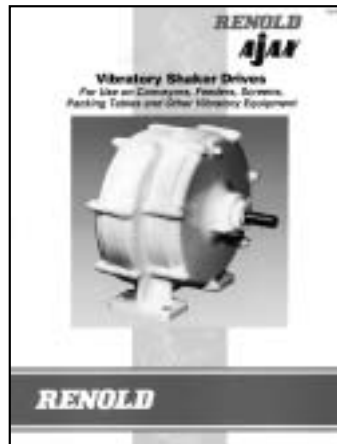

ELECTRIC VIBRATORS

Renold's Rotary Electric Vibrators are economical and reliable motor-based vibratory devices. No other vibrator delivers more value and quality per pound of force output. We offer a variety of models operating at frequencies of 900, 1200, 1800 and 3600 RPM. Adjustable eccentric weights allow you to vary the output force. The R/KB-KC Series can also be used as drives for vibratory feeders, screeners and compaction tables.

